

Small Character Ink Jet Printing

- **Longest running time with no interruption**
- **Quick start and stop — no maintenance**
- **Minimal downtime with automatic nozzle cleaning**
- **Unique no mess, no waste fluid delivery system**



More Starts and Stops, Least Operator Intervention

The Videojet 1310 Ink Jet Printer

The Videojet 1310 ink jet printer delivers maximum uptime for your marking and coding operation. This printer is designed to stop and start without additional maintenance, and its automated nozzle cleaning function minimizes downtime. Advanced features allow for high quality print in nearly any environment.



Wash-down and solvent resistant keyboard

Backlit monochrome display

IP53 stainless steel cabinet

Compact, stainless steel printhead

Superior Reliability

The Videojet 1310 printer is engineered to provide clean, consistent print without added maintenance or cleaning procedures. The advanced printhead design includes an automatic cleaning procedure of the nozzle and ink return line at every start and stop, and at regular intervals when the printer is idle. This process ensures the printhead is always ready to deliver clear, highly readable codes for your application.

Quick Set Up, Consistent Printing

The one-button start feature in the Videojet 1310 printer allows for quick start up, to get your line up and running. The automatic priming and setting of the ink pressure and nozzle drive gets the unit into print mode faster, without operator intervention. To further increase uptime, the heated printhead maintains proper ink consistency, important for applications that experience frequent or extreme temperature changes.

No-Mess, No Waste Ink System

The Videojet 1310 printer utilizes an advanced fluid delivery system that reduces mess and waste, which saves you time and money. Specifically designed no-mess bottles guarantee ink and make up fluid are fully deposited into the fluids reservoirs, avoiding spills or leaks. The hydraulic system slides out to allow for easy access and flushing, reducing downtime associated with this process.

Easy to Use

The simple user interface and text-editor software in the Videojet 1310 provide a common look and feel to Videojet's other industrial ink jet printers, reducing the time necessary to train operators. Included CompactFlash® memory cards make set-up, back up, cloning and upgrading to multiple units quick and easy.



Problem-Free Coding

The Videojet 1310 runs longer without maintenance and is designed to be more tolerant of frequent starts and stops. This system offers seven bar code types and an on-board logo editor, so logos do not need to be created off-line and then downloaded to the printer. An internal photo-eye allows for continuous printing, without the need for extra hardware.

Videojet TotalSource® Services

The **TotalSource** system is the finest and most complete technical support program in the business. It includes everything from expert applications assistance, operator training and a full spectrum of maintenance services. The TotalSource program ensures total customer satisfaction.

Support when and where you need it



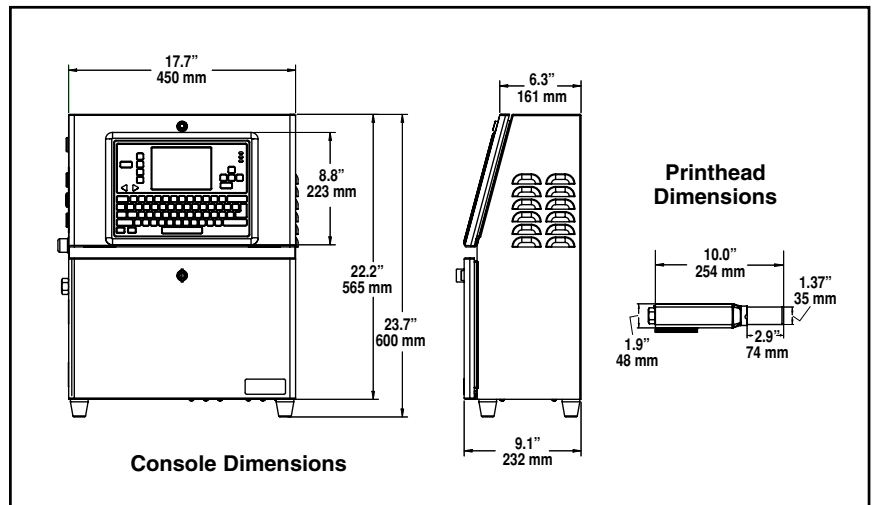

Specifications

Line Speed Capability

(10 characters per inch, single line of print)
Can print 1 to 3 lines of print in speeds of up to 279.1 m/min. (916 ft./min.)

For precise speeds/matrices that relate to your specific application, please contact your Videojet Sales Representative.

Print Rate

Up to 1,833 characters per second, depending on font selections.

Font Matrix Configuration

Single-line: 5x5, 5x7, 7x9, 7x10, 10x16, 16x24, 20x32

Twin-line: 5x5, 5x7, 7x9, 10x16

Tri-line: 5x5, 5x7, 7x10

Linear Bar Codes

Interleaved Two of Five (ITF 2 of 5)
EAN 8 & 13; UPC A; Code 128; EAN 128;
Code 39

Nominal Character Height

Selectable from 1.67mm (0.066 inches) to 11.5 mm (0.452 inches) at 3/16" throw distance, depending on matrix selected

Keyboard

Membrane style with tactile feedback including 70 numeric, alphabetic, and special function keys. PC style layout, to approximate international PC convention. Keyboard is wash-down and solvent resistant.

Display

320 x 240 backlit monochrome display
144mm (5.7") measured diagonally
Display is wash-down and solvent resistant

Custom Logo/Graphics

Can be created by individual user

Languages

Screen prompts and keyboard templates are independently selectable, via software, allowing users to instantly switch between loaded languages. There are 24 individual languages supported.

Data Interface

Connector™ via RS232, RS485 and Ethernet with optional hardware
Optional Remote Data serial port

Message Storage

Can store up to 100 messages

Console Dimensions

Stainless steel, rated IP53
600mm (23.7") high
450mm (17.7") wide
232mm (9.1") deep

Printhead

Compact Stainless Steel
Cylindrical portion: 35mm (1.37") diameter;
74mm (2.9") length
Rectangular portion: 48mm (1.9") diameter;
181mm (7.16") length

Printhead Cable

Flexible PVC tubing, reinforced by rigid PVC spiral
Dimensions: Length 3m (9.84 ft); Diameter 26.7mm (1.05 in)
Bend radius: 178mm (7 in) min

Fluids/Consumption

Wide range of formulations and colors. Up to 78 million char/liter (5x7) or 46.8 million char/600ml cartridge (5x7), depending on ink and selected attributes.

Fluids Containers

One 600 ml liter ink bottle
One 750 ml make up bottle

Temperature/Humidity Range

40° F to 113° F (5° C to 45° C),
10% to 90% RH without condensation

Electrical Requirements

Nominal supply power 90 to 260 VAC at 50/60 Hz., 105 watts max.

Approximate Weight

Unpacked and dry: 49 lbs. (22 kg)
Packed and with fluids: 54 lbs. (24.5 kg)

CERTIFIED
ISO 9001
DOCUMENTED QUALITY



© 2005 Videojet Technologies Inc. – All rights reserved.
Videojet Technologies Inc.'s policy is one of continued improvement. We reserve the right to alter design and/or specifications without notice. Videojet, and TotalSource are registered trademarks and Connector is a trademark of Videojet Technologies Inc. CompactFlash is a registered trademark of the CompactFlash Association.



• www.videojet.co.uk • uksales@videojet.com

Videojet Technologies Limited • 4 & 5 Ermine Centre • Lancaster Way
Huntingdon • Cambridgeshire • PE29 6XX • United Kingdom
Phone: 0870 240 5542 • Fax: 0870 242 2835

Part No. SL000417
VJ1310-0905
Printed in U.K.